

DiVi. MONOLITHIC & SEGMENTED PANEL SYSTEM



**UNRIVALED BENEFITS.
UNMATCHED PRICEPOINT.**

DiVi is designed to be the most cost-efficient monolithic and segmented panel system on the market.

It offers unrivaled benefits, including panels in permanent monolithic, segmented, glass, and stack configurations. The universal hinge connection system makes DiVi one of the quickest panel systems to install; its flexible polypropylene hinge ensures quick and easy panel connections. With this unique connection system, it's simple to construct 60/120 degree or 45/135 degree environments without unique connectors.

- 1 Large 6" high raceway with optional power & data separation septum accommodates up to 100 Cat 5 or Cat 6 cables.
- 2 Easily integrate power & data in a single raceway reducing cost and unnecessary powered panels.

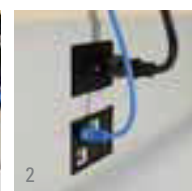
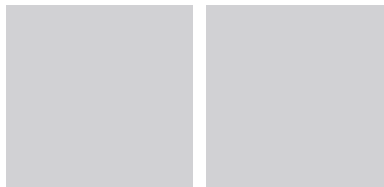

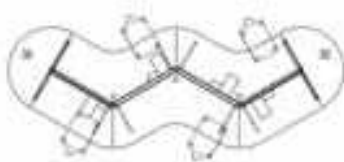

FINISHES:

Paint: Grey Value 1
Fabrics: Jhane Barnes Textiles - Ishi, Color: Bamboo;
Guilford - Shagreen, Color: Poseidon
Laminate: Pionite - Hard Rock Maple
Edgeband: Hard Rock Maple

FLEXIBILITY IS KEY.

DiVi's flexibility makes it perfect for every application, making it easy to create sophisticated environments using segmented insert panels.

Segmented insert panels provide users with the freedom to customize each panel to meet their needs. The front and back of each DiVi insert panel can be specified independently, so panels can be monolithic on one side and segmented on the reverse. Panel inserts are conveniently sold as preconfigured options; they require no elevation planning. Unleash your creativity, change fabric insert colors or integrate glass. Each panel is a undefined palette waiting to be designed!

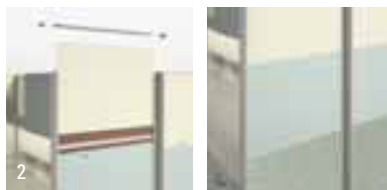

1 Each DiVi panel can accommodate a 16 inch stack unit allowing the user to adjust heights on pre-installed monolithic or skin panels. Stack units are available in fabric and glass.

2 Various panel inserts including fabric, glass, laminate and whiteboard allow for endless design possibilities.

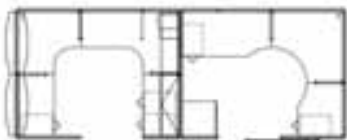

FINISHES:

- Paint: Grey Value 1
- Fabrics: Guilford - Block Party, Color: Isle;
 Guilford - Streetwise, Color: Commuter;
 DesignTex - Cut to the Chase, Color: Alabaster
- Laminate: Formica - Sail White Oxide
- Edgeband: Light Grey

CREATE AN OPEN ENVIRONMENT.

With standard lead times, DiVi offers quarter-glass and half-glass insert panels. Use them to create an increasingly open environment. Quarter-glass panels have 16-inch-high windows and are available at 50-inch, 66-inch and 82-inch heights. Half-glass panels have 32-inch-high windows and are available at 66-inch and 82-inch heights.



- 1 Glass is available with a variety of tinted and textured options.
- 2 Radius overheads are available in solid or perforated steel for economical design. Easy down mechanism can be added for increased ergonomic function.

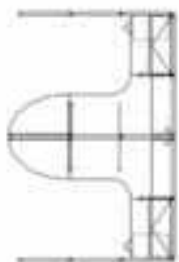

FINISHES:
Paint: Black
Fabric: Guilford - Birdseye, Color: Outlook
Laminate: Formica Rattan Cane
Edgeband: Black

CREATIVELY DESIGNED FOR REUSE.

DiVi is a product of high standards in both engineering and design. Not only was it important to create a cost-efficient, flexible system, but AIS wanted a system that could be reused and one that did not compromise indoor air quality.

DiVi easily adapts to new configurations and reuse. With the universal hinge connection system, panels can be reconfigured with the same hinge. Change fabrics on your insert panels to update the look, add stack-ons to create a more-private office environment, add additional panels and work surfaces to meet the needs of your employees. Whenever you need to refresh, reconfigure or redesign your workplace, DiVi is ready to exceed your needs.

DiVi is also a GREENGUARD-certified product. That means it has been tested and is certified for low chemical emissions and does not contribute to indoor air pollution.

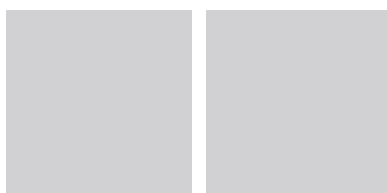
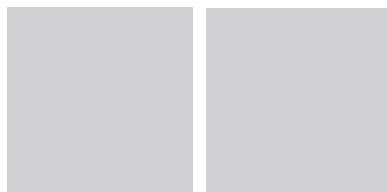

- 1 DiVi insert panels are manufactured with formaldehyde-free materials.
- 2 DiVi consists of 54% to 58% recycled materials by weight.

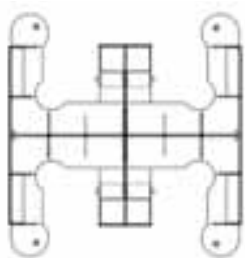

FINISHES:

Paint: Light Tone

Fabrics: Jhane Barnes Textiles - Calligraphy, Color: Light Olive Matte;
Guilford - Anchorage, Color: Green Apple

Laminate: Pionite White

Edgeband: White

SEGMENT OR STACK.

Panel inserts are factory assembled and do not need to be removed for panel installation. Skins can be easily removed and replaced in the field to achieve a new look or to reconfigure your space.

Each DiVi panel can accommodate a 16-inch stack unit, allowing the user to adjust heights on preinstalled monolithic or skin panels. Stack units are available in fabric and glass.





1



2



3



4



5



6



7

ACCESSORIES

- 1 Enhance your workspace. New Radius Flipper doors provide an increased aesthetic to any workstation. Available in solid or perforated steel in any AIS standard paint color. Standard front flipper doors are also available to meet a lower pricepoint.
- 2 Tool Rails are an efficient, easy to incorporate solution to keep workspace areas neat and clean. Paper flow tools are available in several styles to meet your needs.
- 3 Mid-height shelves and whiteboards can be integrated to truly customize any employee's workspace.
- 4 Element Task is offered in black as a standard, and is now available with a sliver mesh back and enhanced silver base.
- 5 Wardrobe Towers with integrated filing are a great way to conceal jackets and miscellaneous items.
- 6 AIS Standard Loop Pull pedestals are available in Box/Box/File and File/File Configurations.
- 7 Mobile Pedestals with optional cushion seat are available in a Box/File configuration.

DATA & ELECTRICAL

DiVi has a high-capacity, six-inch-tall base raceway that will meet all your power and data needs. An optional metal septum divides the raceway into two three-inch-high-by-two-inch-deep upper and lower cavities to separate low-voltage and high-voltage cables, if required.

Quad access base covers have two duplex outlet locations at the top and two data port access holes at the bottom. This unique feature provides electrical and data access in the same panel. The standard AIS eight-wire, four-circuit electrical system provides either 3 + 1 or 2 + 2 power options.

The DiVi data device plate accommodates up to six Hubbel Cat 5, Cat 5E or Cat 6 data jacks. The hinged base raceway assembly slides flat under the installed panels and folds up to enclose the cables after cable installation. This provides easy lay-in cabling.

DiVi's durable system of corner shrouds finishes panel junctions at 90, 60/120 and 45/135 degree angles to seal the raceway cavity and hide data and electrical cables.





CONNECTIONS/CONFIGURATIONS

The DiVi universal hinge connection system can accommodate 90, 60/120 or 45/135 degree space planning without requiring any unique connectors. Every panel comes with the hinges required to install the panel at any of these angles.



STORAGE AND FILE SOLUTIONS

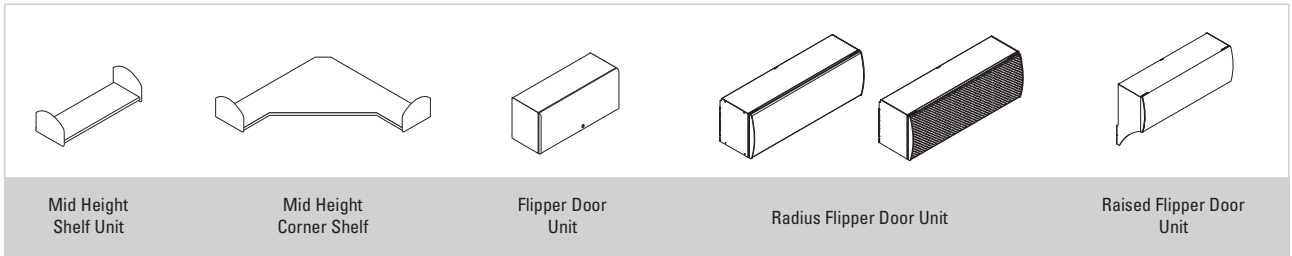

SHELVES / FLIPPER DOORS

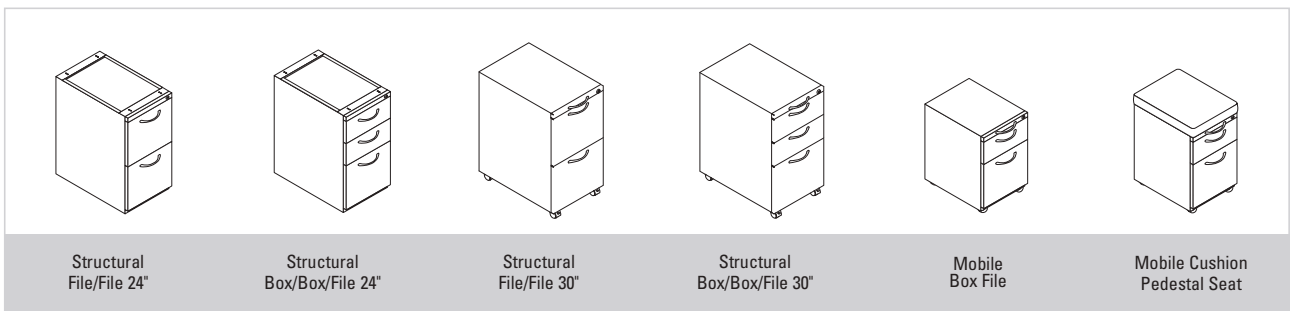

PEDESTALS

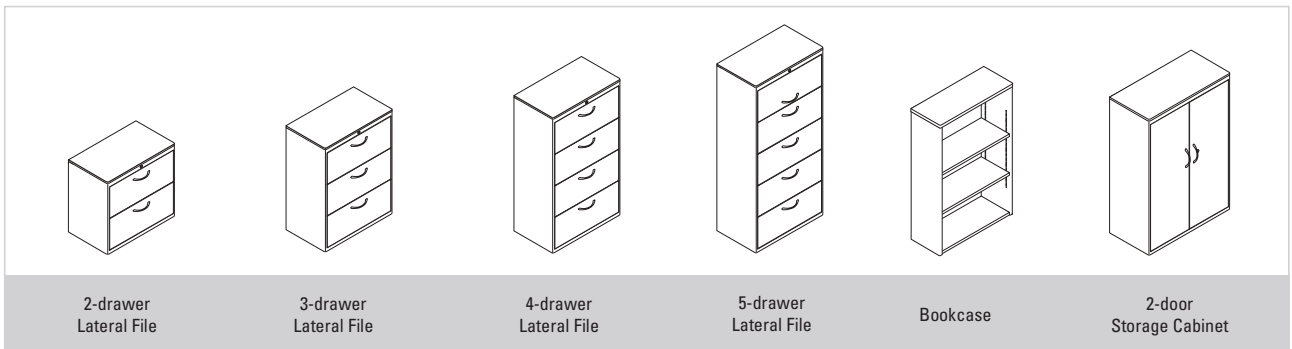

BOOKCASES, 2-DOOR CABINETS LATERAL FILES

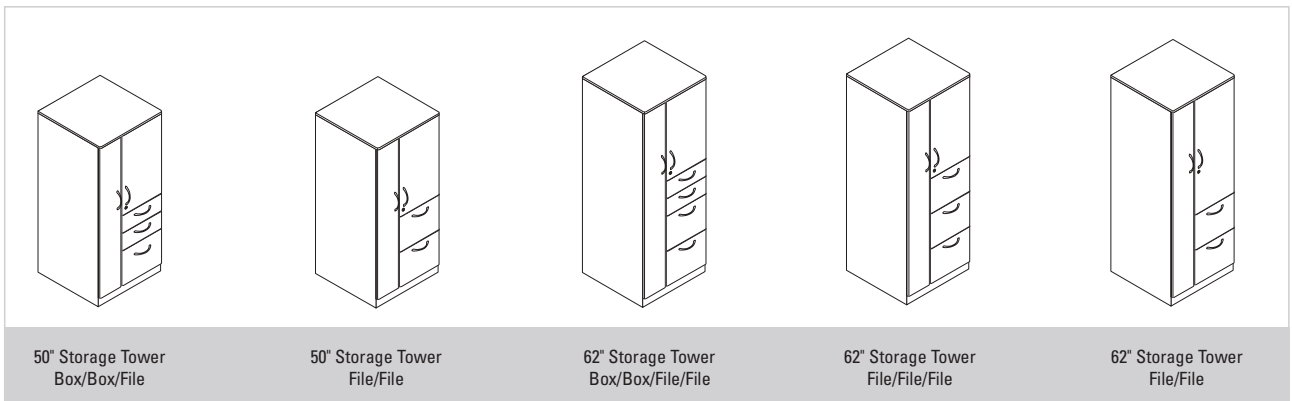

WARDROBE STORAGE TOWERS



THE STANDARD.
FOR ANY ENVIRONMENT.

DiVi offers you an exceptional value for your work environment even as AIS sets a high standard for preserving and improving the world's environment. For several years, in fact, we have led our industry in developing and implementing Green and Lean manufacturing practices. A testament of our commitment is being the first and only systems furniture manufacturer to be awarded the prestigious Shingo Award for excellence in lean manufacturing. By working with like-minded suppliers, we have pioneered efforts in eliminating waste and reducing potentially harmful toxins and VOCs. AIS also adheres to the stringent GREENGUARD standards and engineers and manufactures its products with this standard in mind. We will continue to devote ourselves to manufacturing lean products that are sensitive to the environment and indoor air quality.



4 Bonazzoli Avenue Hudson, MA 01749
800.434.7400 978.562.7500 Fx 978.562.0811
www.ais-inc.com

For additional information on AIS:
Dealer Showrooms
Representative Directory
Project Case Studies
Online Catalog & Product Showcase
Visit: www.ais-inc.com

© 2007 Affordable Interior Systems, Inc. (AIS). All rights reserved, printed in USA.

